

---

**Agilent Technologies  
355C, D, E, F  
VHF Attenuators**

**Operating and Service  
Manual**

---



00355-90051

**Agilent Part Number: 00355-90051**  
**Printed in USA**  
**April 2002**  
Supersedes: November 2001

---

## Notice

The information contained in this document is subject to change without notice.

Agilent Technologies makes no warranty of any kind with regard to this material, including, but not limited to, the implied warranties of merchantability and fitness for a particular purpose. Agilent Technologies shall not be liable for errors contained herein or for incidental or consequential damages in connection with the furnishing, performance, or use of this material.

Agilent Technologies assumes no responsibility for the use or reliability of its software on equipment that is not furnished by Agilent Technologies.

This document contains proprietary information which is protected by copyright. All rights are reserved. No part of this document may be photocopied, reproduced, or translated to another language without prior written consent of Agilent Technologies.

### Restricted Rights Legend

Use, duplication, or disclosure by the U.S. Government is subject to restrictions as set forth in subparagraph (c)(1)(ii) of the Rights in Technical Data and Computer Software clause at DFARS 252.227-7013 for DOD agencies, and subparagraphs (c)(1) and (c)(2) of the Commercial Computer Software Restricted Rights clause at FAR 52.227-19 for other agencies.

### Serial Number Prefix

The specifications in this manual apply to the instruments with the following serial numbers or greater:

Model	Serial Numbers (min.)
355C	2524A44630
355D	2522A46649
355E	1205A38159
355F	1203A03244

© Copyright 1997, 2001, 2002 Agilent Technologies, Inc

---

## What You'll Find in This Manual...

This operating and service manual contains the following:

- Instrument Description and Specifications
- Replaceable Parts and Accessories
- Installation Instructions
- Operating Instructions
- Schematics and Diagrams

---

## Warranty

Custom systems are warranted by contractual agreement between Agilent Technologies and the Customer.

### Certification

*Agilent Technologies certifies that this product met its published specifications at the time of shipment from the factory.*

### Documentation Warranty

THE MATERIAL CONTAINED IN THIS DOCUMENT IS PROVIDED "AS IS," AND IS SUBJECT TO BEING CHANGED, WITHOUT NOTICE, IN FUTURE EDITIONS. FURTHER, TO THE MAXIMUM EXTENT PERMITTED BY APPLICABLE LAW, AGILENT DISCLAIMS ALL WARRANTIES, EITHER EXPRESS OR IMPLIED WITH REGARD TO THIS MANUAL AND ANY INFORMATION CONTAINED HEREIN, INCLUDING BUT NOT LIMITED TO THE IMPLIED WARRANTIES OF MERCHANTABILITY AND FITNESS FOR A PARTICULAR PURPOSE. AGILENT SHALL NOT BE LIABLE FOR ERRORS OR FOR INCIDENTAL OR CONSEQUENTIAL DAMAGES IN CONNECTION WITH THE FURNISHING, USE, OR PERFORMANCE OF THIS DOCUMENT OR ANY INFORMATION CONTAINED HEREIN. SHOULD AGILENT AND THE USER HAVE A SEPARATE WRITTEN AGREEMENT WITH WARRANTY TERMS COVERING THE MATERIAL IN THIS DOCUMENT THAT CONFLICT WITH THESE TERMS, THE WARRANTY TERMS IN THE SEPARATE AGREEMENT WILL CONTROL.

## Assistance

Product maintenance agreements and other customer assistance agreements are available for Agilent Technologies products.

For assistance, call your local Agilent Technologies Sales and Service Office (refer to “Support and Service”).

---

## Support and Service

Any adjustment, maintenance, or repair of this product must be performed by qualified personnel. Contact your local Agilent Technologies sales and service office.

<b>Online assistance:</b> <a href="http://www.agilent.com/find/assist">www.agilent.com/find/assist</a>		
<b>United States</b> <i>(tel)</i> 1 800 452 4844	<b>Latin America</b> <i>(tel)</i> (305) 269 7500 <i>(fax)</i> (305) 269 7599	<b>Canada</b> <i>(tel)</i> 1 877 894 4414 <i>(fax)</i> (905) 282-6495
<b>New Zealand</b> <i>(tel)</i> 0 800 738 378 <i>(fax)</i> (+64) 4 495 8950	<b>Japan</b> <i>(tel)</i> (+81) 426 56 7832 <i>(fax)</i> (+81) 426 56 7840	<b>Australia</b> <i>(tel)</i> 1 800 629 485 <i>(fax)</i> (+61) 3 9210 5947
<b>Malaysia</b> <i>(tel)</i> 1 800 828 848 <i>(fax)</i> 1 800 801 664	<b>Philippines</b> <i>(tel)</i> (632) 8426802 <i>(tel)</i> (PLDT subscriber only): 1 800 16510170 <i>(fax)</i> (632) 8426809 <i>(fax)</i> (PLDT subscriber only): 1 800 16510288	<b>Thailand</b> <i>(tel)</i> outside Bangkok: (088) 226 008 <i>(tel)</i> within Bangkok: (662) 661 3999 <i>(fax)</i> (66) 1 661 3714
<b>Taiwan</b> <i>(tel)</i> 0800-047-866 <i>(fax)</i> (886) 2 25456723	<b>People's Republic of China</b> <i>(tel)</i> (preferred): 800-810-0189 <i>(tel)</i> (alternate): 10800-650-0021 <i>(fax)</i> 10800-650-0121	<b>India</b> <i>(tel)</i> 1-600-11-2929 <i>(fax)</i> 000-800-650-1101

---

## Safety and Regulatory Information

Review this product and related documentation to familiarize yourself with safety markings and instructions before you operate the instrument. This product has been designed and tested in accordance with international standards.

---

### WARNING

---

The **WARNING** notice denotes a hazard. It calls attention to a procedure, practice, or the like, that, if not correctly performed or adhered to, could result in personal injury. Do not proceed beyond a **WARNING** notice until the indicated conditions are fully understood and met.

---

### CAUTION

---

The **CAUTION** notice denotes a hazard. It calls attention to an operating procedure, practice, or the like, which, if not correctly performed or adhered to, could result in damage to the product or loss of important data. Do not proceed beyond a **CAUTION** notice until the indicated conditions are fully understood and met.

## Instrument Markings



When you see this symbol on your instrument, you should refer to the instrument's instruction manual for important information.



This symbol indicates hazardous voltages.



The laser radiation symbol is marked on products that have a laser output.



This symbol indicates that the instrument requires alternating current (ac) input.



The CE mark is a registered trademark of the European Community. If it is accompanied by a year, it indicates the year the design was proven.



The CSA mark is a registered trademark of the Canadian Standards Association.

---

1SM1-A

This text indicates that the instruments are an Industrial Scientific and Medical Group 1 Class A product (CISPER 11, Clause 4).

---

This ISM device complies with Canadian ICES-001.  
Cet appareil ISM est conforme à la norme NMB du Canada.



This symbol indicates that the power line switch is ON.



This symbol indicates that the power line switch is OFF or in STANDBY position.

---

## **Safety Earth Ground**



This is a Safety Class I product (provided with a protective earthing terminal). An uninterruptible safety earth ground must be provided from the main power source to the product input wiring terminals, power cord, or supplied power cord set. Whenever it is likely that the protection has been impaired, the product must be made inoperative and secured against any unintended operation.

## **Before Applying Power**

Verify that the product is configured to match the available main power source as described in the input power configuration instructions in this manual. If this product is to be powered by autotransformer, make sure the common terminal is connected to the neutral (grounded) side of the ac power supply.

---

## Typeface Conventions

- Italics**
  - Used to emphasize important information:  
Use this software *only* with the xxxxxX system.
  - Used for the title of a publication:  
Refer to the *xxxxxX System-Level User's Guide*.
  - Used to indicate a variable:  
Type `LOAD BIN filename`.
- Instrument Display**
  - Used to show on-screen prompts and messages that you will see on the display of an instrument:  
The xxxxxX will display the message `CAL1 SAVED`.
- [Keycap]**
  - Used for labeled keys on the front panel of an instrument or on a computer keyboard:  
Press `[Return]`.
- {Softkey}**
  - Used for simulated keys that appear on an instrument display:  
Press `{Prior Menu}`.
- User Entry**
  - Used to indicate text that you will enter using the computer keyboard; text shown in this typeface must be typed *exactly* as printed:  
Type `LOAD PARMFILE`
  - Used for examples of programming code:  
`#endif // ifndef NO_CLASS`
- Path Name**
  - Used for a subdirectory name or file path:  
Edit the file `usr/local/bin/sample.txt`
- Computer Display**
  - Used to show messages, prompts, and window labels that appear on a computer monitor:  
The `Edit Parameters` window will appear on the screen.
  - Used for menus, lists, dialog boxes, and button boxes on a computer monitor from which you make selections using the mouse or keyboard:  
Double-click `EXIT` to quit the program.

## Typeface Conventions



---

## General Information

This manual contains operating instructions for 355C, 355D, 355E, and 355F VHF Attenuators. Included in the manual is the information required to install and test these attenuators.

### Description

The Agilent Technologies Model 355C, 355D, 355E, and 355F attenuators are 50-ohm, coaxial step attenuators usable from dc to 1 GHz. Models 355C and 355E provide 0 to 12 dB of attenuation in 1 dB steps.

Models 355D and 355F provide 0 to 120 dB of attenuation in 10 dB steps. The 355C and 355D are manual attenuators. The 355E and 355F are programmable. The schematic for the Model 355C/D is shown in [Figure 1](#), and that of the Model 355E/F in [Figure 2](#).

The attenuator sections consist of resistor pi networks which are switched in or bypassed by microswitches. In the 355C and 355D, the microswitches are actuated by cams (see [Figure 1](#)). In the 355E and 355F, the microswitches are actuated by solenoids (see [Figure 2](#)). The standard RF connectors are BNC type.

In the 355E and 355F, power must be continuously applied to the solenoid to actuate the microswitch (i.e., to insert an attenuator section). Each solenoid draws approximately 0.1A at 15 Vdc.

Dimensions for the individual instruments are provided in [Table 1](#), “Dimensions,” on page 2.

## General Information

---

**NOTE**

---

Dimensions are for general information *only*. If accurate dimensions are required for building special enclosures, contact your nearest Agilent Technologies office.

**Table 1** *Dimensions*

	355C, D	355E, F
Length	152 mm (5.98 in)	137 mm (5.39 in)
Height	69 mm (2.72 in)	72 mm (2.83 in)
Width (without RF connectors)	45 mm (1.77 in)	45 mm (1.77 in)
Width (with connectors):		
Standard (BNC)	73 mm (2.88 in)	73 mm (2.88 in)
Option 001 (Type-N)	94 mm (3.70 in)	121 mm (4.76 in)
Option 005 (TNC)	69 mm (2.72 in)	24 mm (0.94 in)
Protrusion of connectors:		
BNC	14.06 mm (0.55 in)	14.06 mm (0.55 in)
Type-N	24.5 mm (1.00 in)	24.5 mm (1.00 in)
TNC	12 mm (0.47 in)	12 mm (0.47 in)

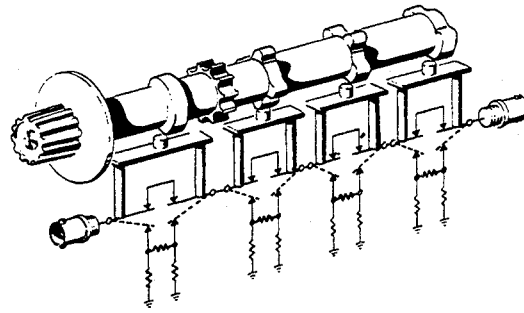

**MODEL 355C**

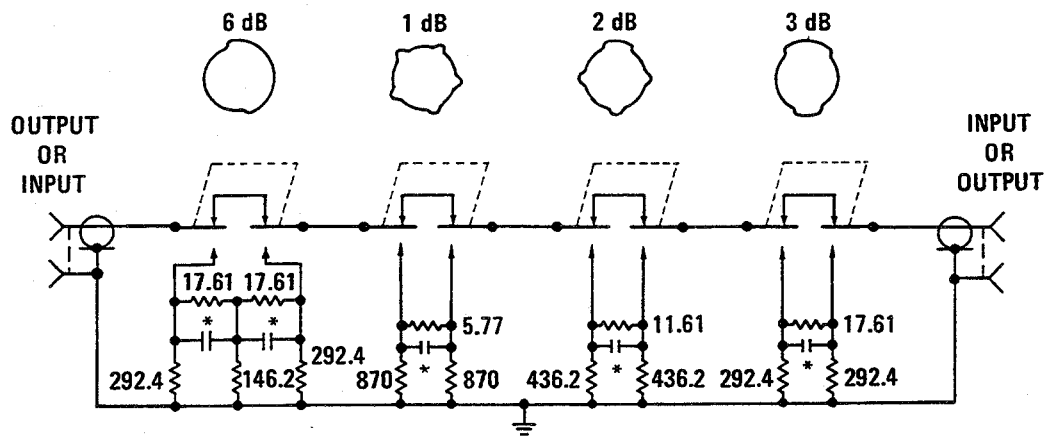

**MODEL 355D**

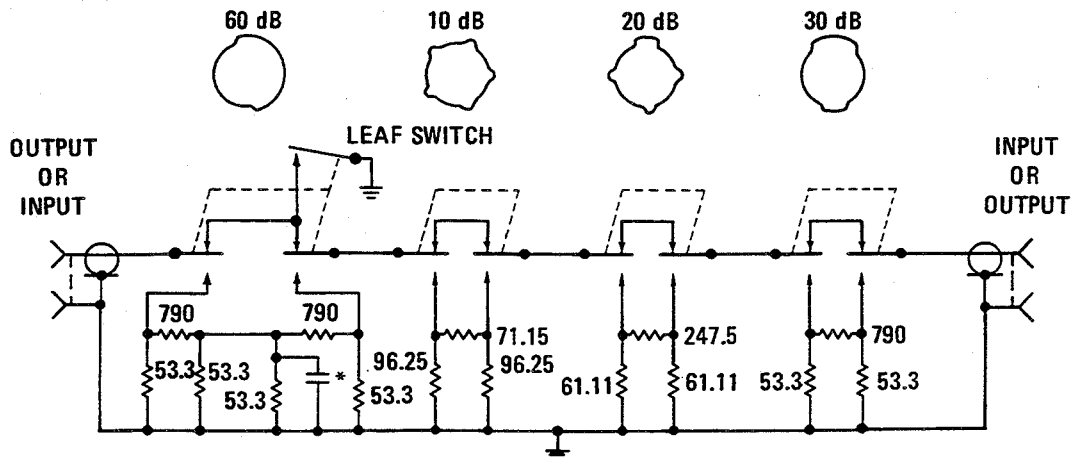

**NOTES**

1. Microswitches shown in 0 dB position.
2. Resistances in ohms ( $\pm 1/2\%$ ).
3. Capacitance values factory-adjusted.
4. \*Asterisk denotes factory selected value.

*Figure 1 355C and 355D Schematic Diagram*

General Information

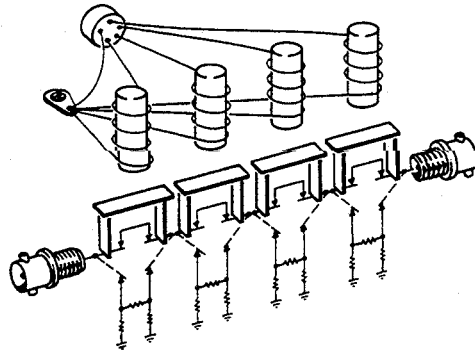

MODEL 355E

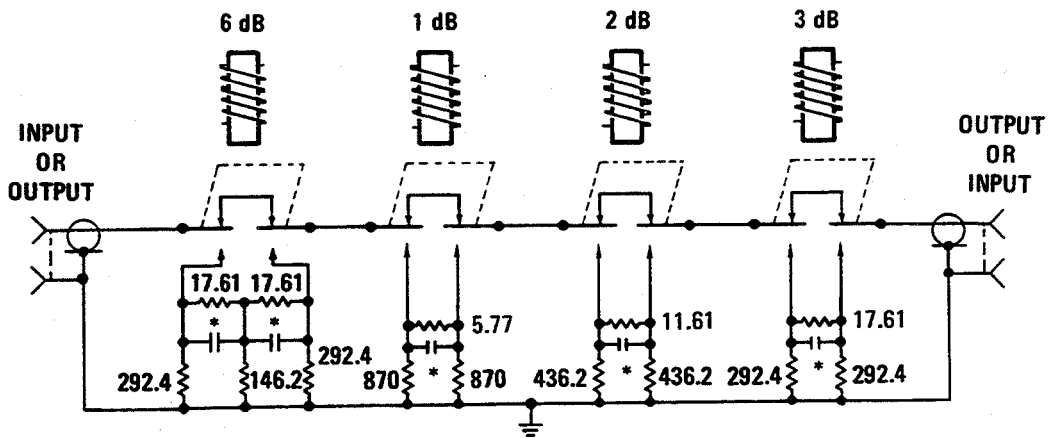

MODEL 355F

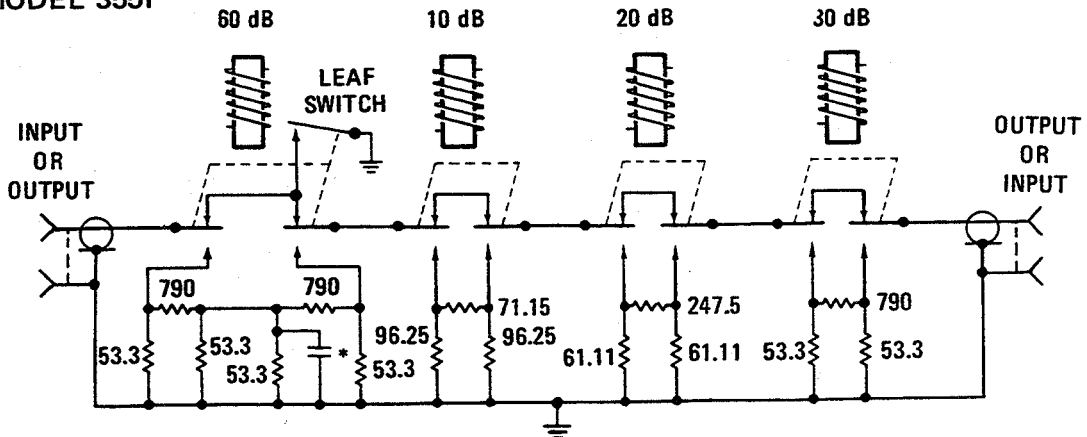

NOTES

1. Microswitches shown in 0 dB position.
2. Resistances in ohms ( $\pm 1/2\%$ ).
3. Capacitance values factory-adjusted.
4. \*Asterisk denotes factory selected value.

Figure 2 355E and 355F Schematic Diagram

## Specifications

Instrument specifications are listed in [Table 2](#). These specifications are the performance standards or limits against which the instruments may be tested.

**Table 2** *Specifications*

<b>MODELS 355C and 355E</b>	
Attenuation Range	0 to 12 dB
Attenuation Steps	1 dB
Overall Accuracy:	
at 1000 Hz	0.1 dB
dc to 500 MHz	0.25 dB
dc to 1000 MHz	0.35 dB
<b>MODELS 355D and 355F</b>	
Attenuation Range	0 to 120 dB
Attenuation Steps	10 dB
Overall Accuracy:	
at 1000 Hz	0 to 120 dB 0.3 dB
below 1000 MHz	0 to 90 dB 1.5 dB
	90 to 120 dB 3 dB
<b>MODELS 355E and 355F</b>	
Switching Speed	65 ms
Required Solenoid Power	+15 to +18 Vdc, 1/8 A
<b>MODELS 355C/E and 355D/F</b>	
Frequency Range	dc to 1000 MHz
Impedance	50 ohms (nominal)
Maximum SWR (input and output):	
below 250 MHz	1.2
below 500 MHz	1.3
below 1000 MHz	1.5
Maximum residual attenuation (insertion loss at 0 dB)	0.20 dB + 2.30 dB/GHz
Maximum power dissipation	0.5W (average)
Maximum pulse voltage	350 Vpk 200 sec
Connectors	
Standard	BNC (female)
Option 001	Type-N (female)
Option 005	TNC (female) <sup>1</sup>

1. Available on the 355C only.

## Power Rating

---

### CAUTION

---

Do not exceed the RF power rating of 0.5W average, or 2450W peak with a maximum pulse width of 200  $\mu$ s. Do not connect an attenuator RF input or output connector to greater than 5 Vdc. If the attenuator must be connected to a device with a potential greater than 5 Vdc, use a blocking capacitor.

## Accessories Supplied

The 355E and 355F programmable attenuators are supplied with a 7-pin, male connector (1251-1037) for the solenoid drive input.

## Attenuator Options

[Figure 3 on page 7](#) shows solenoid and connector wiring diagrams available under Option 007 for 355E and 355F.

# Attenuator Options

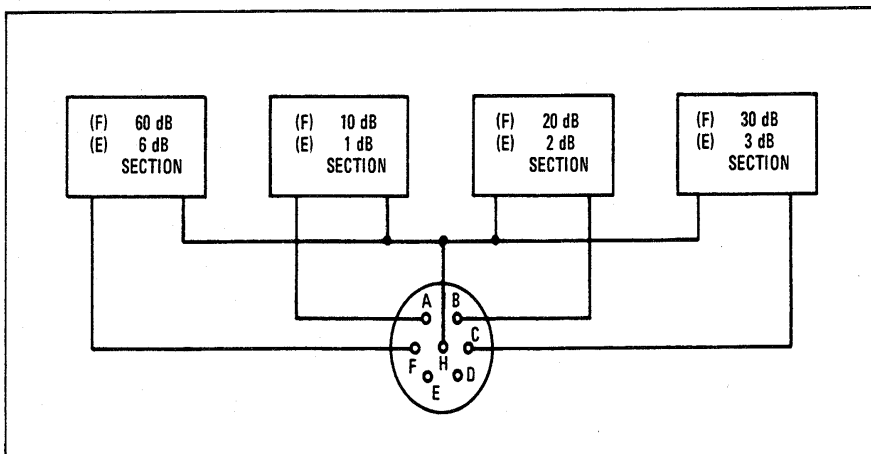
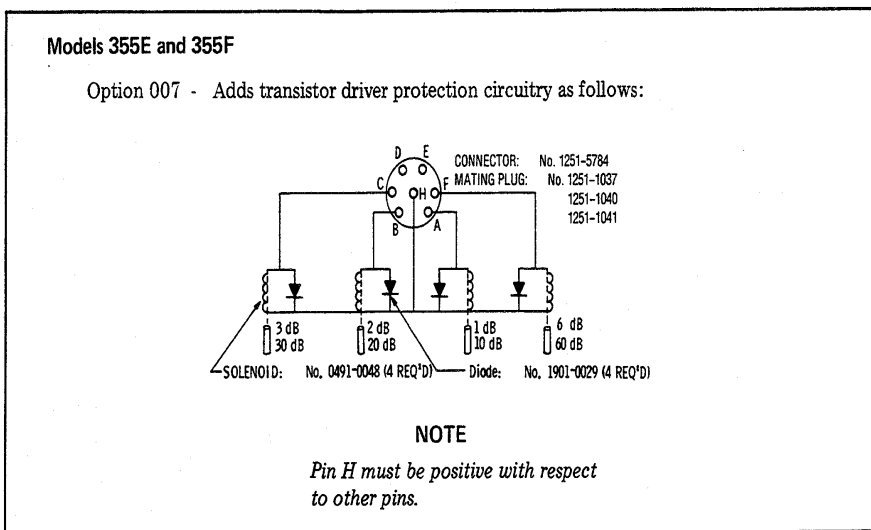

To obtain attenuation settings given below, apply +15 to +18 Vdc between Pin H (common) and Pins:

355E	355F	Pins	355E	355F	Pins
1 dB	10 dB	A	7 dB	70 dB	F, A
2 dB	20 dB	B	8 dB	80 dB	F, B
3 dB	30 dB	C	9 dB	90 dB	F, C
4 dB	40 dB	C, A	10 dB	100 dB	F, C, A
5 dB	50 dB	C, B	11 dB	110 dB	F, C, B
6 dB	60 dB	F	12 dB	120 dB	F, C, B, A

Figure 3 355E and 355F Solenoid and Connector Wiring Diagrams

---

## Installation

### Initial Inspection

Inspect the shipping container for damage. If the shipping container or cushioning material is damaged, it should be kept until the contents of the shipment have been checked mechanically and electrically. A procedure for checking electrical performance is given under “[Operator’s Check](#)” on [page 9](#) (also see “[Performance Tests](#)” on [page 12](#)). If the contents of the shipment are incomplete, if there is mechanical damage or defect, or if the instrument does not pass the electrical performance test, notify the nearest Agilent Technologies office. Keep the shipping materials for the carrier's inspection.

### Mating Connectors

Mating RF input and output connectors used with the attenuators should be:

- Standard . . . . . Type BNC
- Option 001 . . . . . Type-N
- Option 005 . . . . . Type TNC

For the 355E and 355F, the solenoid drive connector plug is 7-pin male connector (1251-1037).

### Operating Environment

The operating environment of the instrument should be within the following limitations:

- Temperature . . . . . 0° to +55 °C
- Humidity . . . . . <95% relative
- Altitude. . . . . <4,570 m (15,000 ft)

### Storage and Shipment

#### Environment

The instrument should be stored in a clean, dry environment. The following environmental limitations apply to both storage and shipment:

- Temperature . . . . . –40° C to +75 °C
- Humidity . . . . . < 95% relative
- Altitude. . . . . < 7,620 m (25,000 ft)

#### Original Packaging

Containers and materials identical to original packaging are available from Agilent Technologies. If the instrument is being returned to Agilent Technologies, attach a tag indicating the type of service required, return address, model number, and serial number. Also, mark the container FRAGILE to assure careful handling. In any correspondence, refer to the instrument by model number and full serial number.



---

## Operating Instructions

---

### CAUTION

---

Do not apply RF power greater than 0.5W average, or 2450W peak with a maximum pulse width of 200  $\mu$ s. If these limits are exceeded, the attenuator may be damaged.

Either RF connector may be used as the input or output connector, except in the case of the 355D/F driven from a low impedance source. This is because the leaf switch (Figures 1 and 2) may be closed before the microswitch opens when the dial is switched from 50 dB to 60 dB. Should this occur, a momentary short is placed across the connector, inviting damage to either the microswitch or the signal source. Therefore, if the signal source is subject to damage by a short, use the rear most connector for the input. (The dial or solenoid connector is at the front of the attenuator.) This pads the momentary short with 50 dB of isolation. For the 355E and 355F, wire the solenoid drive plug supplied using Figure 3 as a wiring guide. An un-energized attenuator solenoid section is 0 dB. Apply +1.5 to +18 Vdc (with respect to pin H) to energize an attenuator solenoid. A programming table is also given in Figure 3.

### Operator's Check

This section describes the procedures for the operator to make a quick check of the attenuator prior to use or if a failure is suspected.

---

### NOTE

---

Troubleshooting consists of performing the following Operator's Check. If the instrument does not perform within limits, return the instrument to the nearest Agilent Technologies office.

### Description

The attenuator is driven from a 50-ohm signal source at 1 kHz. The output level from the attenuator is detected by a narrow-bandwidth voltmeter (that is, the SWR meter). The attenuator and detector range switches are stepped together and the variations in level noted. This verifies that each attenuator section is being properly switched and checks the low frequency accuracy of the attenuator.

---

### NOTE

---

The SWR Meter used in this check is calibrated for a square-law detector and therefore the range changes and errors (read in dB) are twice that indicated by the meter.

## Operating Instructions

### Quick-Check Procedures

1. Connect equipment as shown in [Figure 4](#), with the Attenuator set to 0 dB attenuation.
2. Set Test Oscillator to 0.3 Vrms at 1 kHz.
3. Set the SWR Meter input to XTAL IMPED LOW and the range to 2 dB (expanded) for 355D or 355F or to 10 dB (with 0 dB expand) for 355C or 355E. Adjust its bandwidth to the center of the adjustment range. Fine tune oscillator frequency to obtain the maximum meter indication.
4. Set attenuator and SWR meter range switch as listed in [Figure 3](#), and verify that the SWR meter indicates within the limits shown.

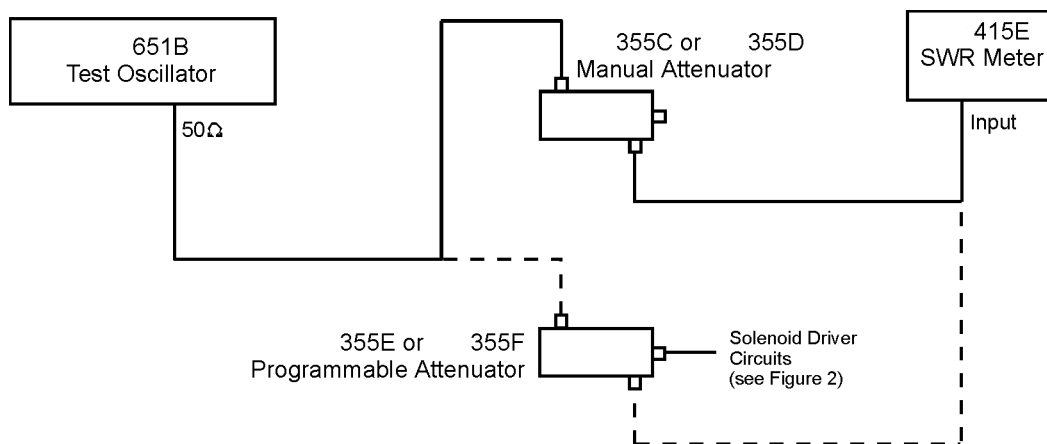

*Figure 4 Operator's Check Schematic*

Table 3 Operator's Checks

355C And 355E				
SWR Meter Range (dB)	Attenuation (dB)	Meter Indication (dB)		
		Min.	Actual	Max.
10	0		Set to 0.0	
10	1	0.45	_____	0.55
10	2	0.95	_____	1.05
10	3	1.45	_____	1.55
10*	4	1.95	_____	2.05
12	5	0.45	_____	0.55
12	6	0.95	_____	1.05
12	7	1.45	_____	1.55
12*	8	1.95	_____	2.05
14	9	0.45	_____	0.55
14	10	0.95	_____	1.05
14	11	1.45	_____	1.55
14*	12	1.95	_____	2.05
355D And 355F				
SWR Meter Range (dB)	Attenuation (dB)	Meter Indication (dB)		
		Min.	Actual	Max.
2	0		Set to 0.5	
6	10	1.35	_____	1.65
12	20	0.35	_____	0.65
16	30	1.35	_____	1.65
22	40	0.35	_____	0.65
26	50	1.35	_____	1.65
32	60	0.35	_____	0.65
36	70	1.35	_____	1.65
42	80	0.35	_____	0.65
46	90	1.35	_____	1.65
52	100	0.35	_____	0.65
56	110	1.35	_____	1.65
62	120	0.35	_____	0.65
*Adjust range by 2 dB, if needed to obtain an on-scale indication.				

### Performance Tests

The attenuator can be tested to the accuracy of the specifications in [Table 1](#) with an Automatic Network Analyzer or equivalent equipment of suitable accuracy. If an Automatic Network Analyzer is available, test the attenuator using the procedures in the analyzer's operating manual. The 355E and 355F attenuators must be programmed by a suitable circuit to provide the various values of attenuation (see [Figure 3](#)).

### Adjustments

The attenuators have no internal adjustments and should not be opened. If defective, the attenuator should be returned to the nearest Agilent Technologies office for repair.

---

### CAUTION

---

The solenoids in the 355E and 355F have been precisely adjusted at the factory. No attempt should be made to replace them except by factory approved service representatives. The operation of the attenuators will be unreliable if plungers are not kept with their proper solenoids. Do not interchange or "swap" them.

---

## Replaceable Parts

Table 4 lists the replaceable parts which are the only parts that can be replaced without access to the interior of the attenuator. For any parts needing replacement that are not listed in Table 4, return the instrument to Agilent Technologies.

---

### CAUTION

---

Due to special fixtures necessary for assembly, do NOT attempt to replace any parts not listed in Table 4. If the instrument is opened, the warranty is void.

**Table 4** *Replaceable Parts*

Description	Part Number	Quantity
<b>355C</b>		
Glide (feet)	0403-0026	4
Dial Assembly	0370-3070	1
Dial Assembly (Option 003)	00355-00001	1
<b>355D</b>		
Glide (feet)	0403-0026	4
Dial Assembly	0370-3071	1
Dial Assembly (Option 003)	00355-00002	1
<b>355E and F</b>		
Glide (feet)	0403-0026	4
Connector (7-pin, male)	1251-1037	1